

### ANTENNA FEATURES

- Log periodic 5 elements 5.5 dBd gain.
- Vertical or horizontal polarization.
- Broadband 87.5÷108 MHz.
- Directional radiation pattern.
- Aluminum or stainless steel version.

### RADIATION PATTERNS (Mid Band)

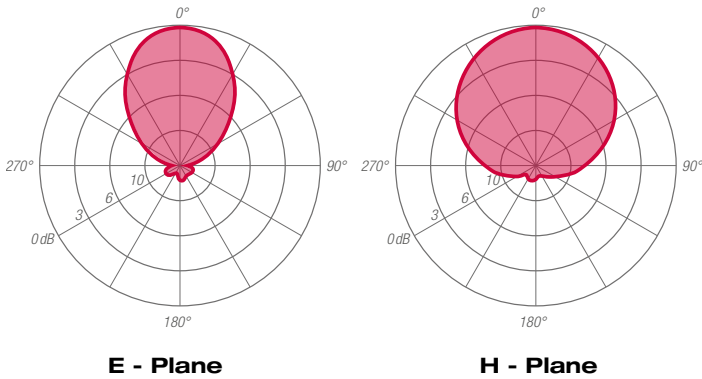

### GAIN (dB)

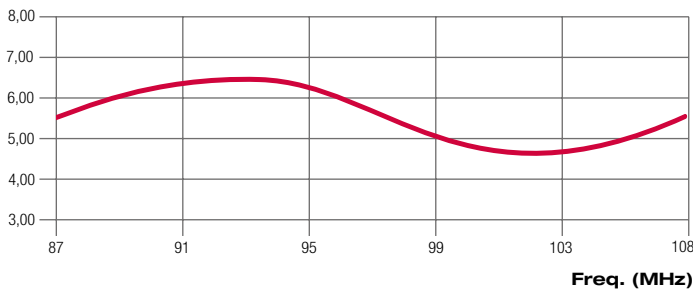

### VSWR

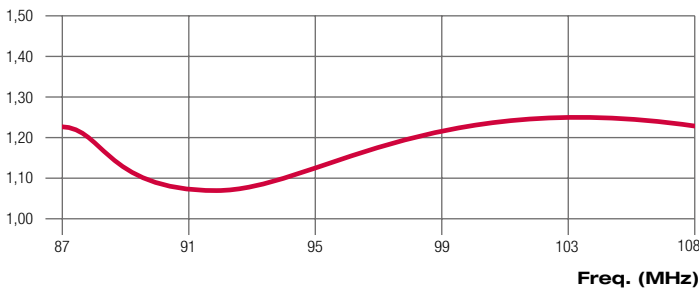

### ELECTRICAL DATA

WORKING BAND:	87.5 - 108 MHz
BANDWIDTH:	VHF band FM
GAIN:	5.5 dBd (7.7 dBi)
VSWR:	≤ 1.23:1 (-19.7 dB)
POLARIZATION:	Linear (Vertical or Horizontal)
IMPEDANCE:	50 Ohm unbalanced
HALF POWER BEAMWIDTH:	E-Plane - 66° H-Plane - 106°
LIGHTNING PROTECTION:	All metal parts DC grounded including inner conductors
AVAILABLE VERSION AND CODE:	ALP0502710- EIA 7/16 female - max 3000W rms ALP0502711- N - max 800W rms ALP0502712- EIA 7/8" flange - max 5000W rms ALP0502730- N - max 800W rms* ALP0502731- EIA 7/16 female - max 3000W rms* ALP0502732- EIA 7/8" flange - max 5000W rms*

(\*) Safety parafil kit included

### MECHANICAL DATA

MATERIALS:	Stainless steel version (ALP050273X) Aluminum version (ALP020721X) Hot dip galvanized steel brackets and bolts
MOUNTING:	Directly on supporting structure
MOUNTING BRACKETS:	Included for Ø60÷114mm pipe (Ø 2.36" - 4+1/2")
ICING PROTECTION:	Optional radome (code XRALPFM5)
TREATMENTS:	Powder painted elements and body grey color - RAL 7001 (version ALP050271X) Silver-plated lines and connector
PRESSURIZATION:	No
ANTENNA DIMENSIONS:	1716x1432x129 mm (62.2x56.3x5.07 in) (ALP050271X) 1736x1432x129 mm (68.3x56.3x5.07 in) (ALP050273X)
ANTENNA WEIGHT:	15.1 kg (33.2 lb) (Version ALP050273X) 8.5 (18.7 lb) (Version ALP050271X)
WIND SURFACE:	0.11m <sup>2</sup> (1.18ft <sup>2</sup> ) front - 0.19m <sup>2</sup> (2.04 ft <sup>2</sup> ) side
WIND LOAD (160 km/h and 30°C)	0.08 kN front - 0.19 kN side
SURVIVAL WIND:	220 km/h (136.7 mph)
PACKING DIMENSIONS:	Box 1950x1630x150mm - 24kg (Version ALP050273X) (76.7x64.1x5.9 in - 52.9lb) Box 1950x1630x150mm - 10 kg (Version ALP050271X) (76.7x64.1x5.9 in - 22.04lb)
SPECIAL FEATURES	Optional brackets side-by-side arrays (code XSTLOG-PER)

Specification are subject to change without notice



### ARRAY FEATURES

- Directional
- Equal or unequal power distribution system
- Configurable for specific azimuth and elevation pattern
- Suitable for multiplexing many channels

### ARRAY ELECTRICAL DATA

FREQUENCY RANGE	87.5 ÷ 108 MHz
IMPEDANCE	50 ohm
CONNECTOR	EIA flange according to system power rating
POWER RATING	The antenna system can accept any power according to requirements
VSWR	≤ 1.17 in the operating channels or ≤ 1.23 throughout the frequency range Antenna system VSWR value also depending from the supporting structure
POLARIZATION	Vertical (or horizontal upon request)
GAIN	Refer to table
HORIZONTAL PATTERN	Any type according to requirement
VERTICAL PATTERN	Null fill, beam tilt and special requirements to order
OTHER FEATURES	Antenna components and feed harnesses can be optimized for channels of interest.

### ARRAY MECHANICAL DATA

HEIGHT OF ARRAY	Subject to number of bays
TOTAL NET WEIGHT	Refer to table
WIND LOAD	Refer to table
PRESSURIZABLE	No
MOUNTING HARDWARE	Optional mounting for side mount configuration

### ANTENNA DIMENSIONAL DETAILS

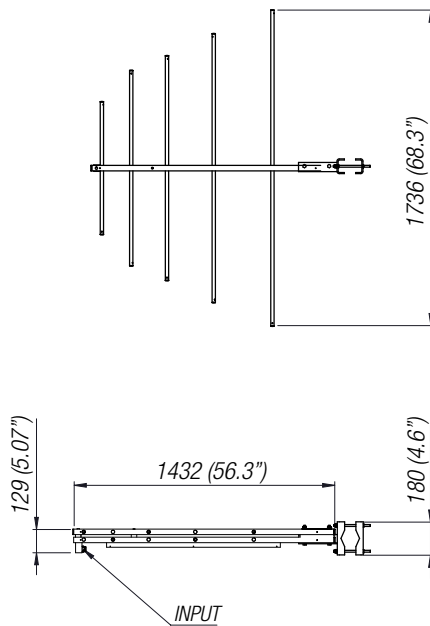

### ARRAY TECHNICAL DATA

BAYS	PANELS PER BAY	GAIN <sup>(1)</sup> dB	GAIN TIMES <sup>(1)</sup>	WEIGHT <sup>(2)</sup> kg (lb)	ANTENNA HEIGHT <sup>(L)</sup> m (ft)	WIND LOAD <sup>(3)</sup> kN
2	1	8.5	7.08	27 (59.5)	4.1 (13.4)	0,60
4	1	11.5	14.13	49 (108.0)	9.5 (31.1)	1,19
6	1	13.3	21.38	72 (158.7)	14.9 (46.5)	1,79
8	1	14.5	28.18	116 (255.7)	20.3 (48.8)	2,39
12	1	16.3	42.66	164 (361.5)	31.1 (102.0)	3,58

- (1) Gain data is relative to half-wave dipole. Values given are nominal and assume standard harness configurations  
Gain will vary depending in specific feed system, null fill and beam tilt.  
(2) Referred to Aluminum model ALP050271X and without mounting hardware.  
(3) 160 km/h (100 mph) wind and 30°C (86°F) air temperature.  
(L) Total Antenna Height.

### OPTIONS & SERVICES

PATTERN DESIGN	Custom azimuth and elevation (beam tilt and null fill) patterns can be designed to meet specific protection/coverage requirements
PATTERN CERTIFICATION	Proof-of-performance factory test and pattern measurements on ALDENA test plan area
MOUNTING HARDWARE	Turn-key antenna delivering Tower top/side spine Special hardware/brackets
TRANSMISSION LINE	Transmission line system design and layout
COMBINERS/FILTERS	Combiners/Filters to suit requirements can be supplied
CALCULATION SERVICES	Coverage/interference simulations EM Near Field control and reduction (Environmental impact studies)
ON-SITE SERVICES	Site Survey and Inspection Installation/commissioning and supervising Drive test & EM Field strength measurements After sales maintenance
TRAINING	Technical training certification and consultancy

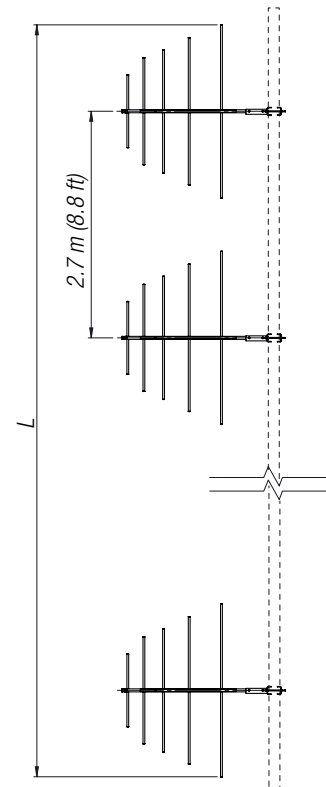

Note:  
Total Antenna Height (L) is subject to change according to requirement.  
Custom designed antennas meeting special requirements such as specific azimuthal pattern, different gains and custom power input are available upon request.

Specification are subject to change without notice