

ANTENNA FEATURES

- Yagi 2 elements antenna.
- Vertical or horizontal polarization.
- Broadband 87.5÷108 MHz.
- Directional radiation pattern.
- Hot dip galvanized steel or aluminum version.

RADIATION PATTERNS (Mid Band)

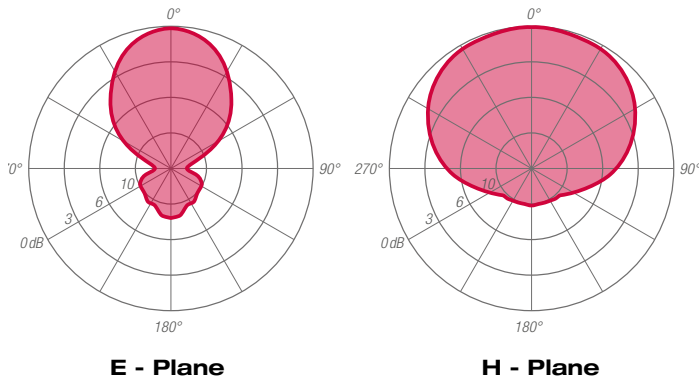

GAIN (dB)

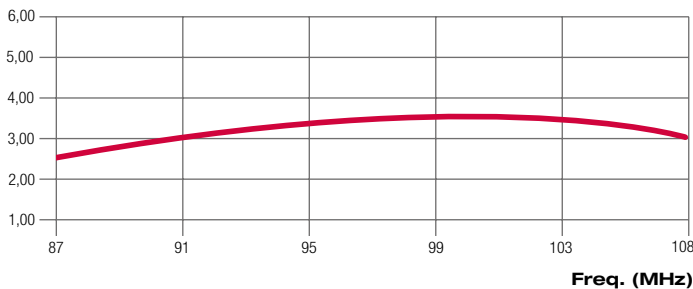

VSWR

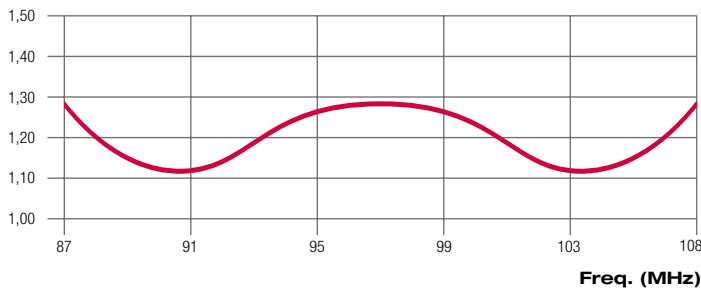

ELECTRICAL DATA

WORKING BAND:	87.5 - 108 MHz
BANDWIDTH:	VHF band FM
GAIN:	3.3 dBd (5.45 dBi)
VSWR:	≤ 1.28:1 (-18.0 dB)
POLARIZATION:	Vertical (or horizontal upon request)
IMPEDANCE:	50 Ohm unbalanced
HALF POWER BEAMWIDTH:	E-Plane - 73° H-Plane - 161°
LIGHTNING PROTECTION:	All metal parts DC grounded including inner conductors
AVAILABLE VERSION AND CODE:	ASR0202320 - N - max 800W rms ASR0202321 - DIN 7/16" female - max 3000W rms ASR0202322 - EIA 7/8" - max 5000W rms ASR0202322A - EIA 7/8" 90° UP/DOWN 5000W rms ASR0202311 - DIN 7/16" female - max 3000W rms ASR0202312 - EIA 7/8" - max 5000W rms ASR0202312A - EIA 7/8" 90° UP/DOWN 5000W rms

MECHANICAL DATA

MATERIALS:	Hot dip galvanized steel body (ASR020232X Version) Aluminum body (ASR020231X Version) Aluminum internal lines
MOUNTING:	Directly on supporting structure
MOUNTING BRACKETS:	Included for Ø60÷114mm pipe (Ø 2.36" - 4+1/2")
ICING PROTECTION:	Optional feed point radome (code XRADE)
TREATMENTS:	Hot dip galvanized steel antenna body. Silver-plated lines and connector
PRESSURIZATION:	No
ANTENNA DIMENSIONS:	1850x1280x50mm (72.8x50.4x1.93 in)
ANTENNA WEIGHT:	15 kg (33.0 lb) (ASR020232X Version) 8 kg (17.6 lb) (ASR020231X Version)
WIND SURFACE:	0.09m ² (0.96ft ²) front - 0.22m ² (2.36 ft ²) side
WIND LOAD (160 km/h and 30°C)	0.07 kN front - 0.17 kN side
SURVIVAL WIND:	220 km/h (136.7 mph)
PACKING DIMENSIONS:	Box 1900x1600x150mm - 19 kg (74.8x62.9x5.9 in - 41.8 lb)

Specification are subject to change without notice



ARRAY FEATURES

- Directional
- Equal or unequal power distribution system
- Configurable for specific azimuth and elevation pattern
- Suitable for multiplexing many channels

ARRAY ELECTRICAL DATA

FREQUENCY RANGE	87.5 ÷ 108 MHz
IMPEDANCE	50 ohm
CONNECTOR	EIA flange according to system power rating
POWER RATING	The antenna system can accept any power according to requirements
VSWR	≤ 1.17 in the operating channels or ≤ 1.28 throughout the frequency range Antenna system VSWR value also depending from the supporting structure
POLARIZATION	Vertical (or horizontal upon request)
GAIN	Refer to table
HORIZONTAL PATTERN	Directional
VERTICAL PATTERN	Null fill, beam tilt and special requirements to order
OTHER FEATURES	Antenna components and feed harnesses can be optimized for channels of interest.

ARRAY MECHANICAL DATA

HEIGHT OF ARRAY	Subject to number of bays
TOTAL NET WEIGHT	Refer to table
WIND LOAD	Refer to table
PRESSURIZABLE	No
MOUNTING HARDWARE	Optional mounting for side mount configuration

ANTENNA DIMENSIONAL DETAILS

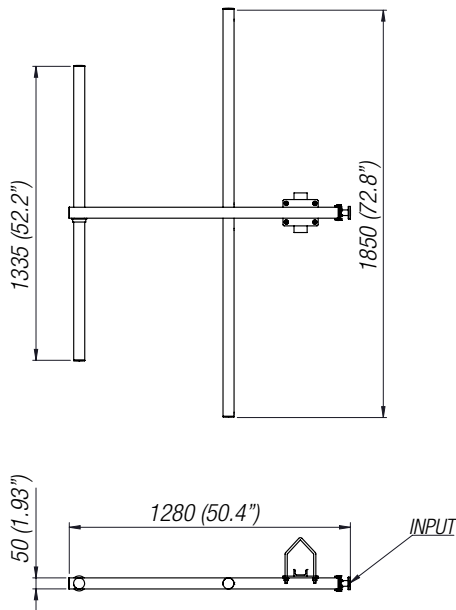

ARRAY TECHNICAL DATA

BAYS	PANELS PER BAY	GAIN ⁽¹⁾ dB	GAIN TIMES ⁽¹⁾	WEIGHT ⁽²⁾ kg (lb)	ANTENNA HEIGHT ^(L) m (ft)	WIND LOAD ⁽³⁾ kN
2	1	6.48	4.45	48 (105.8)	4.4 (14.4)	0,36
4	1	9.56	9.04	86 (189.5)	9.6 (31.4)	0,71
6	1	11.33	13.58	124 (273.3)	14.8 (48.5)	1,06
8	1	12.57	18.07	172 (379.1)	20.0 (65.6)	1,42
12	1	14.34	27.16	248 (546.7)	30.5 (100.0)	2,13

(1) Gain data is relative to half-wave dipole. Values given are nominal and assume standard harness configurations
Gain will vary depending in specific feed system, null fill and beam tilt.

(2) Referred to Hot dip galvanized steel model ASR020232X and without mounting hardware.

(3) 160 km/h (100 mph) wind and 30°C (86°F) air temperature.

(L) Total Antenna Height.

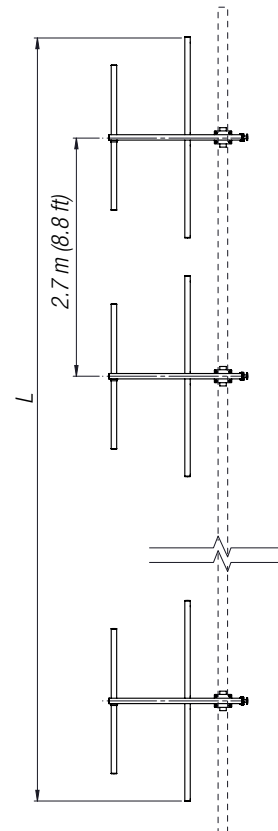

Note:
Total Antenna Height (L) is subject to change according to requirement.
Custom designed antennas meeting special requirements such as specific azimuthal pattern, different gains and custom power input are available upon request.

OPTIONS & SERVICES

PATTERN DESIGN	Custom azimuth and elevation (beam tilt and null fill) patterns can be designed to meet specific protection/coverage requirements
PATTERN CERTIFICATION	Proof-of-performance factory test and pattern measurements on ALDENA test plan area
MOUNTING HARDWARE	Turn-key antenna delivering Tower top/side spine Special hardware/brackets
TRANSMISSION LINE	Transmission line system design and layout
COMBINERS/FILTERS	Combiners/Filters to suit requirements can be supplied
CALCULATION SERVICES	Coverage/interference simulations EM Near Field control and reduction (Environmental impact studies)
ON-SITE SERVICES	Site Survey and Inspection Installation/commissioning and supervising Drive test & EM Field strength measurements After sales maintenance
TRAINING	Technical training certification and consultancy

Specification are subject to change without notice